

# VeriDri™

## Panametrics Moisture Transmitter



### Applications

VeriDri is a loop-powered dew point temperature or PPMv moisture transmitter intended for OEM applications such as:

- Regenerative desiccant air or gas dryers
- Plastic drying applications
- Medical air dryers
- Glove box monitoring

### Features

- Low-cost
- Thin-film aluminum oxide moisture sensor technology
- Microprocessor-based, all-digital technology for reliable operation
- Compact size
- Type 4X/IP67
- Loop-powered 4 to 20 mA output
- -130°F to 70°F (-110°C to 20°C) dew point temperature/0 to 10,000 PPMv moisture (with constant pressure) overall range capability
- National Institute of Standards and Technology (NIST) traceable calibration



## For OEM Applications

The VeriDri moisture transmitter provides dryer manufacturers and other OEMs with the means to make simple, accurate and reliable moisture measurement of their gas at a competitive price.

VeriDri is a loop-powered 4 to 20 mA output transmitter, offered in a number of factory-configured output ranges covering an overall moisture range of -130°F to 70°F or -110°C to 20°C dew point temperature. It is also available in a number of PPMv moisture output ranges with an overall range of 0 to 10,000 PPMv moisture, when operating at a constant pressure. Operating pressure information must be provided to the factory at the time of order placement.

## Improve Product Efficiency and Performance

VeriDri can be used to significantly improve the energy and efficiency of regenerative gas dryer systems. By monitoring the dryer outlet moisture content, desiccant bed regeneration can be initiated on demand, rather than on a timed cycle. This process has been adopted by many major dryer manufacturers, and has resulted in improved performance and significant savings in energy costs. In addition, VeriDri can be used to monitor overall dryer operation, determine regular maintenance intervals and detect faulty operation.

## Advanced Moisture Sensor Technology

The VeriDri combines a technologically advanced aluminum oxide moisture sensor with state-of-the-art software and electronics for unequaled overall performance.

## NIST-Traceable Calibration

Superior sensitivity, speed of response, calibration stability, and wide dynamic range have made GE aluminum oxide moisture probes the standard of performance and value in industrial moisture measurement. They are suitable for laboratory and industrial moisture measurement applications in gases and non-aqueous liquids over a wide range of process conditions.

All moisture probe calibrations are traceable to the NIST.

## Installation Flexibility for OEM Applications

The rugged, compact VeriDri transmitter is designed specifically for OEM installations where space is at a premium. It can be installed directly in the process stream or, if necessary, in a sample system. If required, GE can design and build a sample conditioning system to meet unique application demands.

The VeriDri transmitter is available with OEM pricing for a minimum quantity of 10 units. Discounts on larger quantities are also available, and blanket orders are accepted.

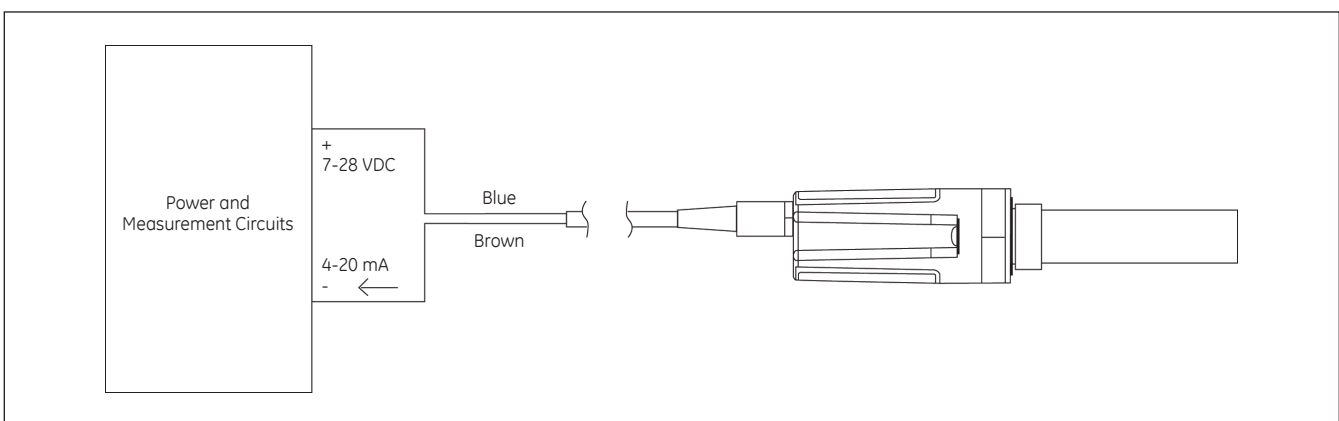

Loop-powered VeriDri wiring diagram

# VeriDri Specifications

## Moisture Ranges

- -110°C to 20°C
- -110°C to -50°C
- -90°C to 10°C
- -80°C to 20°C
- -80°C to -30°C
- -30°C to 20°C
- -130°F to 70°F
- -130°F to -40°F
- -40°F to 70°F
- -100°F to 0°F
- -50°F to 50°F
- 0 to 10 PPMv
- 0 to 100 PPMv
- 0 to 1000 PPMv
- 0 to 10,000 PPMv

PPMv ranges are based on constant pressure, provided at time of order placement.

## Operating Temperature

-40°F to 140°F (-40°C to 60°C)

## Storage Temperature

158°F (70°C) maximum

## Warm-Up Time

Meets specified accuracy in three minutes

## Calibrated Accuracy @ 77°F (25°C)

- $\pm 3.6^\circ\text{F}$  ( $\pm 2^\circ\text{C}$ ) from -85°F to 50°F (-65°C to 10°C) dew/frost point
- $\pm 5.4^\circ\text{F}$  ( $\pm 3^\circ\text{C}$ ) from -112°F to -86°F (-80°C to -66°C) dew/frost point

## Repeatability

- $\pm 0.9^\circ\text{F}$  ( $\pm 0.5^\circ\text{C}$ ) from -85°F to 50°F (-65°C to 10°C) dew/frost point
- $\pm 1.8^\circ\text{F}$  ( $\pm 1.0^\circ\text{C}$ ) from -112°F to -86°F (-80°C to -66°C) dew/frost point

## Response Time

Less than five seconds for 63% of a step change in moisture content in either wet-up or dry-down cycle

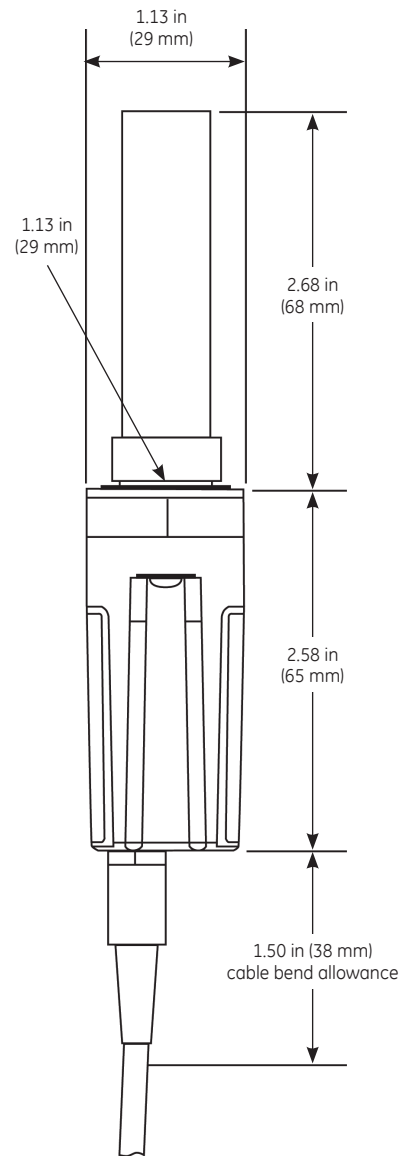

## Electrical

### Power

- 7 to 28 VDC (loop-powered, customer supplied)
- Output: 4 to 20 mA
- Output Resolution: 0.01 mA
- Max Loop R =  $50 \times (\text{PSV} - 7) \text{ W}$   
(Where: PSV = Power Supply Voltage)  
Example: Given a 24 VDC power supply,  
Max Loop R =  $50 \times (24 - 7)$   
= 850 W
- Cable: 6 ft (2 m), standard (consult factory for custom lengths)

## Mechanical

### Sample Connection

- 3/4 in (19 mm) 16 straight male thread with O-ring
- G 1/2 in with optional adaptor

### Operating Pressure

5 Hg to 5000 psig (345 bar)

### Enclosure

Type 4X, IP67

### Dimensions

- Overall: 6.76 in x 1.13 in (172 mm x 29 mm) diameter
- Electronics with cable: 4.08 in x 1.13 in (104 mm x 29 mm) diameter
- Weight: 5 oz (140 grams)

### European Compliance

Complies with EMC Directive 2004/108/EC and PED 97/23/EC for DN<25

## Moisture Sensor

### Sensor Type

Thin-film aluminum oxide moisture sensor probe

### Calibration

Each sensor is individually computer calibrated against known moisture concentrations, traceable to NIST.

### Calibration Interval

Sensor recalibration by GE is recommended every six to 12 months depending on application.

### Flow Rate

Gases: Static to 10,000-cm/s linear velocity at 1 atm



[www.gesensinginspection.com](http://www.gesensinginspection.com)

920-056E