

OVERVIEW BROCHURE

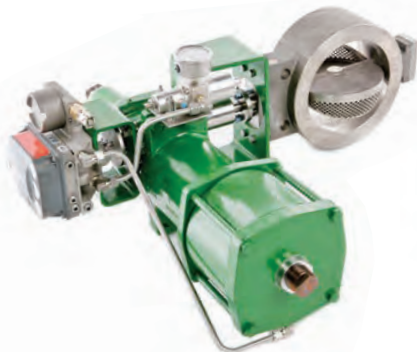

KOSO KENT INTROL SUPPLIES A DIVERSE RANGE OF PRECISION-MANUFACTURED CHOKE, CONTROL AND ROTARY VALVES FOR OIL AND GAS, PETROCHEMICAL AND POWER INDUSTRIES, WORLDWIDE

SCOPE OF DESIGN

KKI specialises in the supply of high-technology surface choke valves, standard and severe-service control valves and rotary valves for the oil and gas, petrochemical and power industries. Complementing these products is the KKI range of actuators and instrumentation.

We have built a reputation for supplying specially designed high quality valves for the most demanding service conditions. It means that we can offer tried and tested valve solutions for problematic applications relating to cavitation, flashing, erosion, high velocity, noise and vibration, as well as for processes that involve high pressures, high temperatures, sub-zero temperatures or solid-contaminated fluids.

Valves are manufactured using a range of materials, from carbon steel to nickel alloys and high strength super-austenitic material. Innovative trims are a crucial element in overcoming the operational conditions encountered in many applications, with advanced designs being developed by our engineers to handle a whole host of pressure, temperature and velocity situations.

Among our range of high performance trims, we offer a multi-turn labyrinth trim design, specifically designed to prevent cavitation erosion, high vibration and noise.

QUALITY MANUFACTURING

Maintaining the highest standards of quality throughout design, production and customer service is the cornerstone of KKI's philosophy.

Our facility is accredited in accordance with Quality Management System ISO 9001, Environmental Management System ISO 14001 and Oil and Gas System ISO 29001. In addition all products, where applicable, conform to ATEX, PED and all other applicable EU directives and are marked accordingly.



SERIES 10 – TOP GUIDED

The series 10 control valve is a robust, heavy section single seated globe/angle valve with a contoured plug to accurately control the flow through the valve. The trim has a high rangeability and gives Class V shut-off capability through metal-to-metal seating. For bubble-tight shut off, Class VI, the plug can be fitted with a PTFE face.



END CONNECTION SIZES

- 1/2" to 12" (15mm to 300mm) as standard

END CONNECTION STYLES

- Flanged
- Socket weld
- Threaded
- Butt weld

VALVE BODY RATINGS

- ANSI 150 to ANSI 600
- Higher on request

DESIGN STANDARD

- ANSI B16.34 / PED certified
- NORSOK / ASME VIII

INHERENT CHARACTERISTIC

- Linear
- Equal percentage
- Quick open

SEAT LEAKAGE

- Class III as standard
- Class IV, V special lapped
- Soft face seat for Class VI shut off

MATERIAL CONSTRUCTION

- Available in most cast materials

FEATURES

- Top guided with no bottom guide to obstruct the seat bore and potentially trap debris
- All trim components are removable from the top
- Large range of trim CVs per valve size

PERFORMANCE

- High flow capacity
- Tight shut off
- Excellent flow control rangeability
- Cast body proportioned to withstand high pipe stresses without distortion

SERIES 20 – DOUBLE SEATED

The series 20 incorporates two seats which results in a higher capacity than the Series 10. The guiding of the plug enables the valve to control higher energy flows in a stable manner. The design can be used for medium and low pressure applications where tight shut off is not important.



END CONNECTION SIZES

- 1 1/2" to 24" (40mm to 600mm)

END CONNECTION STYLES

- Flanged

VALVE BODY RATINGS

- ANSI 150 to ANSI 600 as standard, higher ratings on request

DESIGN STANDARD

- ANSI B16.34/PED certified
- NORSOK/ASME VIII

INHERENT CHARACTERISTIC

- Linear
- Quick open
- Equal percentage

SEATING

- Metal-to-metal for up to Class III shut off

MATERIALS CONSTRUCTION

- Available in most cast materials

FEATURES

- Top and bottom guided
- Anti-cavitation/low noise trim option for high pressure drop applications
- All components serviceable from the top
- Multi-trim sizes available per valve size

PERFORMANCE

- High flow capacity
- Minimum differential plug areas to reduce actuator force requirements
- Excellent flow control rangeability
- Cast body proportioned to withstand high pipe stresses without distortion

SERIES 30 – THREE WAY

The series 30 is used for either mixing or diverting applications. On mixing applications there are two separate inlets with one common outlet. On diverting applications there is one common inlet with two separate outlets.



END CONNECTION SIZES

- 1 1/2" to 12" (40mm to 300mm) nominal bore

END CONNECTION STYLES

- Flanged

VALVE BODY RATINGS

- ANSI 150 to ANSI 600 as standard, higher ratings on request

DESIGN STANDARD

- ANSI B16.34/PED certified
- NORSOK/ASME VIII

INHERENT CHARACTERISTIC

- Linear

SEATING

- Metal-to-metal for up to Class V shut off

MATERIALS CONSTRUCTION

- Available in most cast materials

FEATURES

- Top guided plug with additional skirt guiding through the seat rings, effective on both seats
- Most components serviceable from the top
- Multi-trim sizes available

PERFORMANCE

- High flow capacity
- Minimum differential plug areas to reduce actuator force requirements (Series 31 and 32 valves)
- Excellent flow control rangeability

SERIES 1200 – CAGE GUIDE GLOBES

The Series 1200 is KKI's main globe / angle product suitable for operation over a wide range of applications and operating conditions. This range of valves combines high-integrity features, such as ASME VIII body/bonnet bolting design, a high flow capacity and a wide range of trim designs ideally suited to meet the various critical service process control requirements demanded by a wide range of industry-related applications.

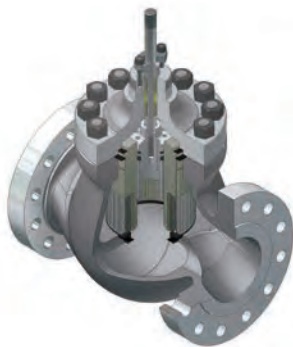

VALVE BODY / END CONNECTION SIZES

- 1" to 24" (25mm to 600mm) nominal bore

VALVE BODY RATINGS

- ANSI 150 to ANSI 4500 (PN10 to PN640)
- API ratings can also be supplied

DESIGN STANDARDS

- ASME B16.34
- ASME VIII
- ASME FCI 70-2 control valve seat
- ASME B16.25 - butt weld end valves
- ASME B16.5 - pipe flanges and flange fittings
- NACE MR-01-75/ISO 15156
- Designs fully PED certified

TRIM DESIGNS

There are a large range of trim designs to cover the wide range of applications encountered in the served industries. The standard design is a low noise/anti-cavitation trim referred to as an HF (High Friction) trim. This is complemented by several multi-stage designs. A labyrinth trim design, VECTOR™, can also be designed and fitted into the S1200 body

BODY MATERIALS

The Series 1200 range can be supplied in the majority of cast alloys as required by the service. All materials used are fully PED certified. Standard materials include:

- Carbon steel - WCB/LCB/LCC
- Stainless steel - CF8M, CF3M, etc
- Chrome moly - WC6, WC9
- Duplex stainless steel - A995 Gr 4A /5A/6A
- High alloys - Monel, Hastelloys, Alloy 625
- Titanium

VECTOR™ – SEVERE SERVICE TRIM

VECTOR™ trims deliver reliable control, long life and freedom from cavitation, erosion, vibration and noise problems. The design has evolved through many decades of experience in solving severe service applications where durability, reliability and control precision are required.

VECTOR™ trims provide many advantages that result in improved performance, reduced maintenance and system simplification.



BODY TYPE

- 1200/500D series

BODY STYLE

- Globe, angle

BODY SIZE

- 1" - 42" (25mm to 1050mm)

BODY RATING

- ASME 150 - 4500 class & API-6A 3000 - 15000

FLUID TEMPERATURES

- -196°C to 620°C (-320° F to 1150° F)

CONNECTIONS

- Flanges (RF, RTJ), butt welded, socket weld, hubs

BODY MATERIALS

- WCB, LCB, LCC, C5, WC6, WC9, C12A, CF3, CF8M, A105, LF2, LF3, F11, F22, F91, F316, 254SMO, duplex, AISI 4130,

TRIM MATERIALS

- Carbon steel, 410 SS, 17-4 PH, F22, F44, F91, 304 SS, 316 SS, Inconel, duplex, tungsten carbide, PSZ (ceramic)

FLOW CHARACTERISTICS

- Linear, modified linear, equal percentage

METAL SEAT LEAKAGE

- Cv x 0.01%, Class IV or V, MSS-SP61

SOFT SEAT LEAKAGE

- Class VI

TRIM STAGES

- Up to 40 stages

SERIES 60 – HIGH PERFORMANCE BUTTERFLY

The rotary valve has been developed by KKI to give a flexible range suitable for a wide range of applications, from benign low pressure drop applications through to some of the most extreme that can be handled by a rotary control valve. All seated valves have uninterrupted 360-degree seal contact in the closed position due to the double offset disc design. With the soft seated valves having a spring-energised, pressure-assisted seal, the valve seating torques are low and seal life is long.



VALVE BODY / END CONNECTION SIZES

- 4" to 36" (100mm to 900mm) nominal bore

VALVE BODY RATINGS

- ANSI 150 to ANSI 600 higher ratings on request

DESIGN STANDARDS

- ASME B16.34
- ASME VIII
- ASME FCI 70-2 control valve seat
- ASME B16.5 - pipe flanges and flange fittings
- NACE MR-01-75/ISO 15156
- Designs fully PED certified

BODY DESIGNS

- Wafer/lugged/double-flanged

TRIM DESIGNS

- Swing through
- Soft seated
- Metal seated
- Rubber lined
- Firesafe
- Rotrol - anti-cavitation

BODY MATERIALS

The Series 60 range can be supplied in the majority of cast alloy materials as required by the service. All materials used are fully PED certified. Standard materials include:

- Carbon steel - WCB/LCB/LCC
- Stainless steel - CF8M, CF3M, etc
- Chrome moly - WC6, WC9
- Duplex stainless steel - A995 Gr 4A /5A/6A
- High alloys - Monel, Hastelloys, Alloy 625
- Titanium

SERIES 73 – SURFACE CHOKE

Koso Kent Introl has been supplying surface choke valves to the oil and gas industry since 1975.



END CONNECTION SIZES

- 1" to 16" (25mm to 400mm)

END CONNECTION STYLES

- Flanged
- Clamp/hub type
- Others on request

CHOKE BODY RATINGS

- ISO 10423 / API 6A 3,000 to 15,000 PSI
- ANSI 600 to 4500

DESIGN STANDARD

- ANS B16.34/API 6A/ASME VIII/PED /ATEX/NACE MR-01-75/NORSOK

MATERIAL OF CONSTRUCTION

- Available in most materials

TRIM OPTIONS

- Cage-guided single and multi-stage velocity control
- Micro and multi-spline for high pressure drop and small flows
- Solid tungsten carbide
- Non-collapsible designs

ACTUATOR OPTIONS

- Manual
- Pneumatic spring return and stepping
- Electric
- Electro-hydraulic
- Hydraulic stepping and hydraulic

SERIES 75 – SUBSEA CHOKE

Koso Kent Introl's Brighthouse facility produced its first subsea choke valve in 1985.



END CONNECTION SIZES

- 2" to 8" (50mm to 200mm)

END CONNECTION STYLES

- Flanged
- Clamp/hub type
- Others on request

CHOKE BODY RATINGS

- ISO 10423/API 6A 5,000 to 15,000 PSI

DESIGN STANDARD

- API 6A/API 17D/ASME VIII/NACE MR-01-75/NORSOK

MATERIAL OF CONSTRUCTION

- Available in most materials

TRIM OPTIONS

- Cage-guided single and multi-stage velocity control
- Solid tungsten carbide
- Non-collapsible designs

ACTUATOR OPTIONS

- Hydraulic stepping
- Manual
- Electric
- Fast close option

RETRIEVAL OPTIONS

- Non-retrieve (for installation into a choke flow module or a choke bridge)
- Diver retrievable
- ROV retrievable

SERIES 1275 – SUBSEA CONTROL VALVE

Koso Kent Introl's Brighthouse facility has been involved with the development of subsea control valves since the late 1980s.



END CONNECTION SIZES

- 2" to 12" (50mm to 300mm)

END CONNECTION STYLES

- Flanged
- Clamp/hub type
- Others on request

VALVE BODY RATINGS

- ISO 10423/API 6A 5,000 to 15,000 PSI
- ANSI 900 TO 4500

DESIGN STANDARD

- API 6A/API 17D/ASME VIII/NACE MR-01-75/NORSOK/ANSI B16.34/PED /ATEX

MATERIAL OF CONSTRUCTION

- Available in most materials

TRIM OPTIONS

- Cage-guided single and multi-stage velocity control
- Micro and multi-spline for high pressure drop and small flows
- Solid tungsten carbide
- Non-collapsible designs

ACTUATOR OPTIONS

- Hydraulic stepping
- Hydraulic modulating
- Manual
- Electric
- Fast close option

AT THE CORE OF THE KOSO KENT INTROL RANGE OF VALVES IS THE HF (HIGH FRICTION) TRIM, FIRST INTRODUCED IN 1969. THE HF TRIM IS SUITABLE FOR THE MAJORITY OF PROCESS CONTROL APPLICATIONS. IT IS A LOW PRESSURE RECOVERY DESIGN THAT PROVIDES BOTH ADVANTAGEOUS CAVITATION ELIMINATION AND NOISE REDUCTION WHEN COMPARED WITH STANDARD PROFILED TRIM DESIGNS.

THE FLOW CAN BE DIRECTED EITHER 'UNDER' THE PLUG (THE FLOW PASSES THROUGH THE SEAT INTO THE INSIDE OF THE CAGE AND THEN THROUGH THE RADIAL HOLES TO THE OUTSIDE OF THE CAGE), OR 'OVER' THE PLUG (THE FLOW PASSES FROM THE OUTSIDE OF THE CAGE, THROUGH THE RADIAL HOLES, TO THE INSIDE OF THE CAGE AND THEN DOWN THROUGH THE SEAT INTO THE VALVE OUTLET). THE FLOW DIRECTION VARIES DEPENDING ON THE PROCESS FLUID.

TRIM OPTIONS

HF – HIGH FRICTION TRIM

For liquid, flows 'over' the plug are preferred. In this case the flow is split into many radial jets and, as the flow passes through the cage, the jets impinge upon themselves within the confines of the cage. This is where the erosion forces will be at their highest and where most of the flow energy can be dissipated. The flow then exits the trim through the valve seat. This means the valve body is protected from the effects of flow erosion. A trim manufactured from harder materials is more capable of handling these erosion forces. On more severe applications (high-pressure drop, contaminated fluids, etc), the trim's operational life can be maintained by using overlays such as stellite or tungsten carbide inserts.

On gas/vapour services, the preferred flow direction is 'under' the plug. The main reason for this is that it has been shown that the acoustic efficiency is lower in this direction. This reduction is attributed to the smaller scale turbulence structure and higher frequency of the flow turbulence, resulting in a greater level of attenuation from the downstream pipe work. This results in a lower transmitted noise on HF trim designs. On the HF family of trims, noise reduction of between 15 to 20dBA can be achieved over a conventional contoured/ported trim. In cases where further noise reduction is required, smaller holes, i.e. 3 or 4mm can be utilised in the cage. This can result in further attenuation between 3 to 10dBA.

MULTI-STAGE – HFL FAMILY

The multi-stage guides, HFL2 (High Friction Double), HFL3 (High Friction Triple) are a design enhancement on the standard HF trim. They are used in applications where noise or cavitation would otherwise be a problem. If not properly controlled, high pressure drop liquid applications can severely damage the valve. To avoid the destructive effects of cavitation, it is necessary to apportion the pressure drop across a number of stages of let down. The HFL2 (two stages) and HFL3 (three stages) apportion the pressure drop equally across either two or three stages of let down. The stages are in the form of concentric sleeves, drilled with radial holes within a number of grooves that form distinct flow galleries. The HFL design, illustrated in Figure 2, incorporates two or more concentric sleeves. Each sleeve has a multitude of grooves incorporating radial holes. The grooves in each sleeve line up to create a tortuous radial flow path. The holes within the concentric sleeves are misaligned to produce a tortuous path through the trim. Energy is dissipated within the cage by the combined effect of flow splitting, flow impingement, and turning of the flow as it passes through the sleeves. There is a large increase in flow area between the stages of let down resulting in a reduction in pressure drop as the flow passes from one stage to the next. This significantly reduces the potential for cavitation, because the final stage of let down has a relatively small pressure drop with its low recovery characteristic. Figure 1 represents the difference between a single stage high-recovery trim, and a three-stage trim with equal stage pressure drop, e.g. the HFL3 design.

FIGURE 1. STAGE PRESSURE DROP

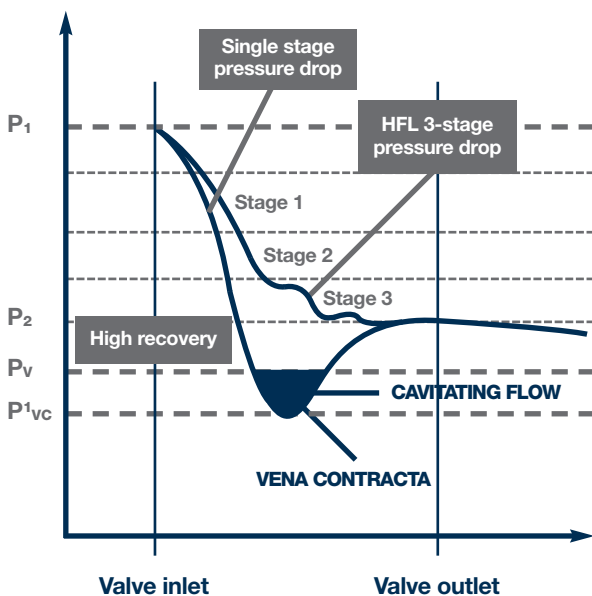

Trim designs are available up to HFL5 (5 stages), as standard. In addition, trims can be characterised to incorporate several different stages of pressure let down over the valve's stroke (i.e. 25% and 50% varistage trims).

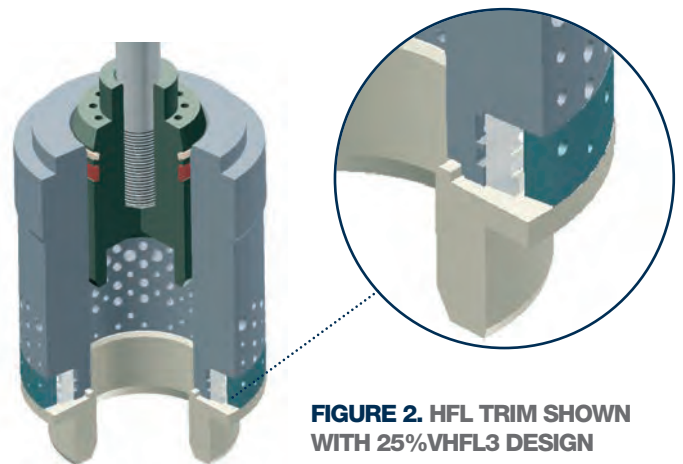

FIGURE 2. HFL TRIM SHOWN WITH 25% VHFL3 DESIGN

AT KOSO KENT INTROL, WE DESIGN AND MANUFACTURE BESPOKE VALVE SOLUTIONS TO SUIT OUR CUSTOMERS' INDIVIDUAL PLANT AND SERVICE REQUIREMENTS. OUR DEDICATION TO CUSTOMERS GOES BEYOND THE SUPPLY OF VALVES, AND INCLUDES A COMMITMENT TO PROVIDING ONGOING SERVICE SUPPORT FOR ALL OF OUR VALVE PRODUCTS – ENSURING THEY DELIVER OPTIMUM PERFORMANCE FOR LIFE.

SERVICE OVERHAUL REPAIR & UPGRADE SOLUTIONS

Through our dedicated service department we offer servicing, overhaul, spare parts supply and upgrade services for valves, chokes and associated instrumentation. Our skilled engineers will overhaul and service valves at our fully equipped workshop in the UK, or on customers' sites – around the world.

WE TAKE CARE OF EVERYTHING

Our team takes full ownership of every project, managing everything from scoping the requirements, transportation and all servicing work, to testing, certification, dispatch and recommendations for future maintenance. It means that working with KKI is simple and hassle-free, with all work carried out efficiently by an experienced team to guaranteed quality standards. Based at our UK headquarters, our flexible, highly motivated and well-qualified service team offers a full range of service support, from commissioning new equipment, routine maintenance and trim overhauls to full valve overhauls and testing.

ANY JOB, ANY SIZE, ANYWHERE

No job is too large or small for our experienced team. Whether you have a single valve that needs servicing or more than 100 valves requiring a complete overhaul, we have the resources, skills and experience to complete your job efficiently, expertly and on time.

INTERNATIONALLY RECOGNISED QUALIFICATIONS

Our service team is fully qualified for UK and international work, and will travel across the world to customer sites, as required. What's more, our engineers are offshore certified to stringent Norwegian standards.

RAPID-RESPONSE SERVICE

The team can be mobilised the same day for UK services or within 24 hours for international requirements, subject to engineer availability. We have dedicated vehicles for site visits, fully equipped with emergency stocks and tooling.

YOUR VALVES IN SAFE HANDS

Our engineers follow the strictest health and safety procedures, both on customer sites and within our workshop facility. We observe rigorous safety precautions when receiving and servicing contaminated valves, actuators or components.

FULLY EQUIPPED WORKSHOP FACILITIES

The dedicated service workshop at our UK factory is capable of handling large shutdowns with fast turn-around times to suit customer requirements. Our workshop facilities include:

- Shot-blast, aqua-cleaning and degreasing machinery to overhaul components to near-new condition
- Multi-functional machines suitable for any shutdown work
- Welding and overlay equipment
- Full inspection facilities, including a coordinate-measuring machine
- Dedicated service test bay with two test rigs, capable of hydro-testing to 15,000psi
- Eleven workstations for flexibility within the workshop
- A 7.5-tonne workshop crane and two one-tonne fixed cranes
- Painting and dye pen facilities
- Gas test facility
- Extensive storage capacity

QUALITY-ASSURED WORK

All completed service work is issued with a final test certificate and a quality plan, identifying the work completed and any future recommendations. The overhaul and servicing procedures we employ mirror those used for manufacturing new valves, ensuring full compliance with PED requirements.

ADVISORY EXPERTISE

As well as servicing work, our team conducts site surveys and offers advice on routine maintenance and plant optimisation.



KOSO KENT INTROL LIMITED
ARMYTAGE ROAD
BRIGHOUSE
WEST YORKSHIRE
HD6 1QF
UK

TELEPHONE
+44 (0)1484 710311

FACSIMILE
+44 (0)1484 407407

EMAIL
info@kentintrol.com

WEBSITE
WWW.KENTINTROL.COM



KOSO

KOSO Kent Introl Limited is part of the KOSO Group of companies.

The company's policy is one of continual development and the right is reserved to modify the specifications contained herein without notice.

Copyright © 2019
All rights reserved KOSO Kent Introl Limited